

The Radio Isotope conventional bypass hood's interior is specifically built and designed for use with radioactive material.

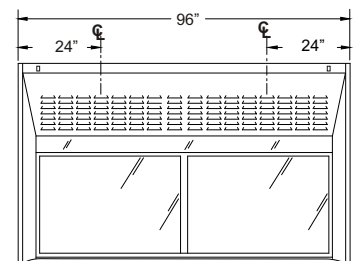
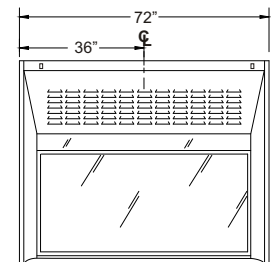
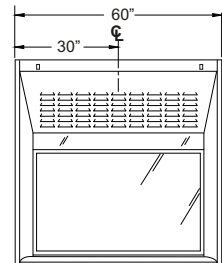
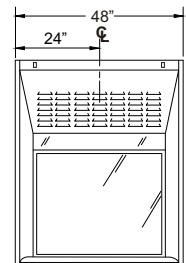
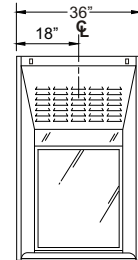

Standard Design

Air Management: Constant exhaust volume, drawing air efficiently through the sash when open or through the bypass opening when sash is closed.

Superstructure: Outer wall is chemically resistant powder coated sheet steel. Double wall construction offers a 5" chase area for easy plumbing and electrical fixture installation. Fixed view panel for maximized visibility.

Interior: Lining is constructed entirely of 16 gauge type 304 stainless steel with No. 4 finish. The integrated dished work top includes a standard 3" x 6" stainless steel cup sink.

Airfoil: Front opening is framed with a 45° angle fascia that substantially reduces the turbulence. The bottom horizontal airfoil directs a current of air at counter top level to purge heavy fumes.

Standard Features

- Fluorescent light fixture (bulbs included) accessed from outside the air chamber
- Stainless steel airfoil
- Stainless steel sash interiors
- Louvered front panel
- VAV styles hoods have restricted bypass

Options

- Sash options
- Plumbing
- Electrical
- Blowers
- Other option

NOTE: The work surface is rated to support 200 lbs per square foot

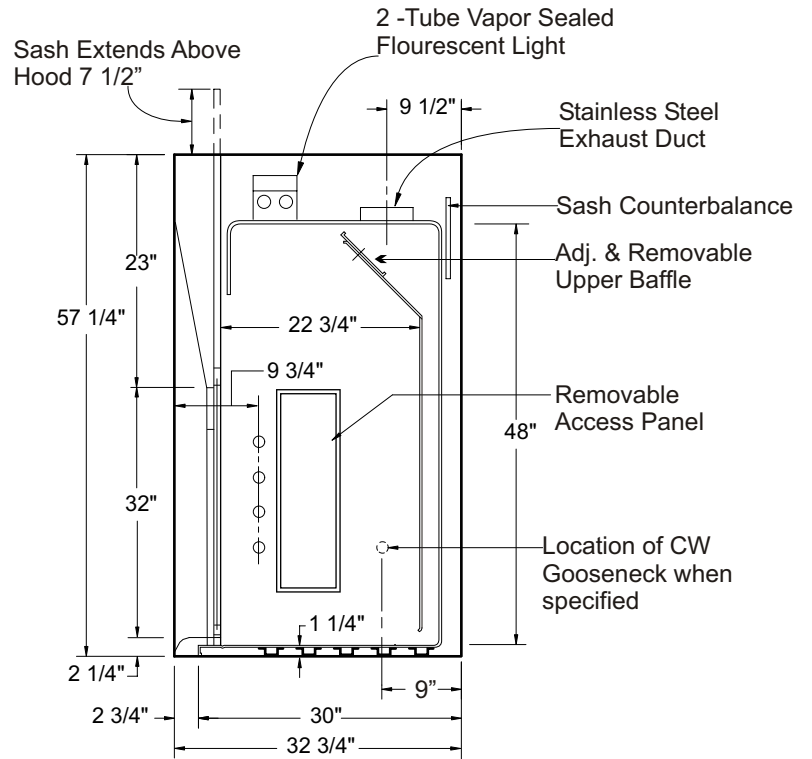
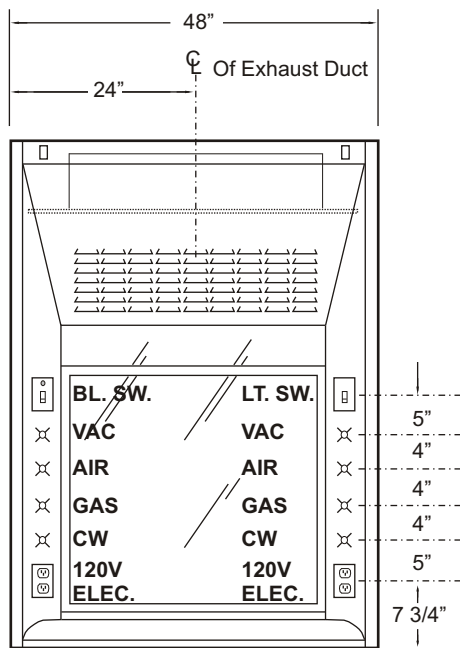

Model	CFM at 100LFM	S.P. at Hood	Duct Size Standard	Duct Size Optional
36MRI	540	.25 inches	8 inches	8" x 10"
48MRI	770	.33 inches	9 inches	8" x 12"
60MRI	1000	.34 inches	10 inches	8" x 16"
72MRI	1250	.34 inches	10 inches	8" x 20"
96MRI	1750	.40 inches	(2) 9 inch ducts	(2) 8" x 12"